

## 925 NANUK

mallettes extrême



### > DÉTAILS TECHNIQUES

matériau :	<b>résine légère NK-7™</b>
poids (vide) :	<b>6.2 lbs (2.8 kg)</b>
quantité par boîte :	<b>1</b>
poids volumique (vide) :	<b>6.2 lbs (2.8 kg)</b>
normes aériennes :	<b>oui</b>
étanchéité :	<b>oui</b>
garantie :	<b>à vie</b>
roulettes :	<b>non</b>

### > DIMENSIONS DE LA MALLETTE

intérieures :	<b>17" x 11.8" x 6.4"</b> <b>(430 x 300 x 160 mm)</b>
extérieures :	<b>18.7" x 14.8" x 7.0"</b> <b>(475 x 375 x 180 mm)</b>

### >> COULEURS



noir 001	graphite 058	argent 039	blanc 002	jaune 036	olive 040	orange 034
-------------	-----------------	---------------	--------------	--------------	--------------	---------------

### >> DIMENSIONS DE LA MALLETTE

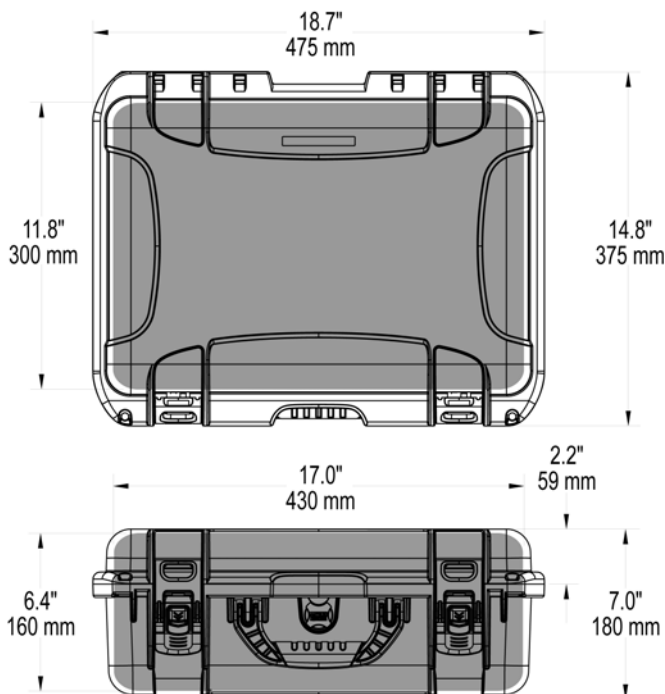

### >> CARACTÉRISTIQUES



> soupape de pression intégrée



> fermetures brevetées Powerclaw™



> poignée caoutchoutée escamotable



> verrouillable



> système intégré d'encastrement



> cran de retenue du couvercle intégré

### >> OPTIONS STANDARDS



> sérigraphie



> calage de polymousse



> calage de mousse personnalisé



> bandouillère

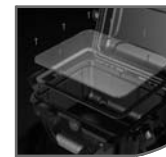

> panneau étanche à l'épreuve de l'eau



> cadenas approuvé par la TSA