

Remove Dirt, Water and Acids From Oils and Fuels

FEATURES

- No tools required for changeout
- Carbon Steel Construction
- 100 psi design pressure
- White powder coat interior and exterior
- Positive O-ring closure

CARTRIDGE SELECTION

Water and Dirt Removal – AC-718 Series **Aquacon**® Cartridges remove both water and dirt from all oils and fuels. SD-718 **Superdri**® Cartridges remove dissolved water from insulating oils.

Acid Removal – LA-71801B Cartridges contain the most effective form of fuller's earth available. LB-71801 Cartridges contain activated alumina. Field proven in vacuum pump oil applications.

Solids Removal – FO-718PL Series high surface area pleated cartridges are the most cost effective for particulate contaminant removal. FOS-618/718PL Series all synthetic media cartridges are also available for particle removal. For removing soft gel-like contaminants, FO-618FGA Series Cartridges with fiberglass depth media are often the most cost effective.

APPLICATIONS

- Insulating Oil
- Hydraulic Oil
- Cutting Oil
- Diesel Fuel
- Kerosene
- Gasoline
- Synthetic Oil
- Vacuum Pump Oil
- Turbine Oil
- Lube Oil
- Water/Glycol
- Biodiesel



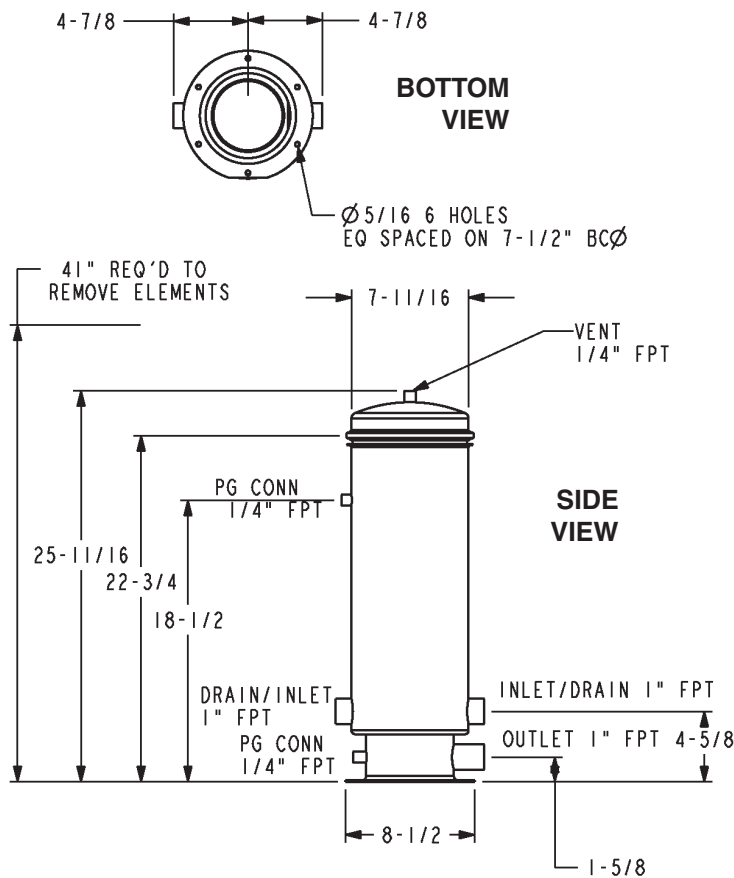

FLOW RATE (USGPM) VS. PRESSURE DROP AT VARIOUS VISCOSITIES FOR EMPTY VF-81E VESSEL (NO CARTRIDGE INSTALLED)

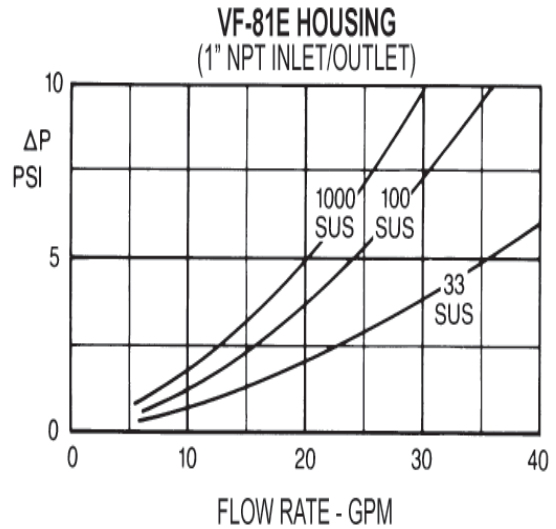

SPECIFICATIONS

14 GA. (2 mm) carbon steel shell
 100 psi (690 k Pa) max operating pressure
 250°F (121°C) design temperature
 Buna-N O-ring lid gasket
 White power coat interior and exterior
 Holds one cartridge

Inlet and outlet – 1" NPT
 Drain – 1" NPT
 Vent and gauge fittings – 1/4" NPT
 Volume without cartridge – 3.8 U.S. gallons (14.4 l)
 Dry weight without cartridge – 22.5 lbs. (10.2 kg)
 Shipping weight – 27 lbs. (12.5 kg)

ORDERING INFORMATION

Specify Model VF-81E Filter Vessel. Unit is shipped as shown with Buna-N Lid Gasket installed but without filter cartridge installed. Desired filter cartridges to be specified separately.

RECOMMENDED SPARES

- 6 filter cartridges
- 1 G-1016 Buna-N lid gasket

Note: If Viton-A® lid gasket is desired, order G-1016A Gasket and replace Buna-N gasket that is installed.



Velcon products are sold and serviced by a world-wide representative network. To order, contact Headquarters or your LOCAL REPRESENTATIVE:

COMPANY HEADQUARTERS:
 Velcon Filters, Inc.
 1210 Garden of the Gods Road
 Colorado Springs, CO 80907-3410
 Phone: 1.800.531.0180 / 1.719.531.5855
 Fax: 719.531.5690
 e-mail: vfsales@velcon.com
 www.velcon.com

MANUFACTURING PLANTS LOCATED AT:
 Colorado Springs, Colorado
 Sylacauga, Alabama

OVERSEAS AFFILIATES:
 Frankfurt/M., Germany & Singapore

**Liquid Filtration
 and Separation
 Specialists**

Due to Velcon Filters' continuing product improvement, drawings, specifications and pictures are subject to change without notice.