



Filter Housings

VF81SYS150

VF82SYS150

Single and Double Element Housings 1½” Inlet/Outlet

STANDARD FEATURES

- Carbon steel construction
- 150 psi design pressure
- 195 psi hydro-test pressure
- Polyurethane almond powder coated interior & exterior
- 1½” NPT female inlet/outlet
- ¾” NPT drain couplings (qty 2)

APPLICATION INFORMATION

50 or 100 gpm maximum flow rates for fuels.
For oils, determine viscosity, then rate based on cartridge flow capacities.

- | | |
|----------------|-----------------|
| Hydraulic Oil | Gasoline |
| Insulating Oil | Transformer Oil |
| Diesel Fuel | Coolant |
| Lube Oil | Cutting Oil |
| Kerosene | Synthetic Oil |
| Gear Oil | Quench Oil |
| Biodiesel | |



VF81SYS150 (left) and VF82SYS150 (right) Filter Housings

ORDERING INFORMATION

Cartridge Types (not included with housings)	FO-718PL Series Pleated Media FO-618FGA Series Fiberglass Depth Media FOS-618 Series Pleated Synthetic Media LA-61801B Fuller's Earth Media AC-718 Series Aquacon ® Water Absorbing Cartridge
Recommended Spares	1 Set of Spare Filter Cartridges 1 Lid Gasket
Accessories	G-1045A Viton Lid Gasket

SPECIFICATIONS

Housing	VF81SYS150	VF82SYS150
Inlet/Outlet	1½" NPT	1½" NPT
A	27 ⁷ / ₈ " (70.8 cm)	46 ¹ / ₈ " (117.2 cm)
B	8 ⁵ / ₈ " (21.9 cm)	8 ⁵ / ₈ " (21.9 cm)
C	3" (7.6 cm)	3" (7.6 cm)
D	1¼" (3.2 cm)	1¼" (3.2 cm)
Vessel Weight – Empty	60 lbs	90 lbs
Shipping Weight	70 lbs	110 lbs
Number of Standard Cartridges	1	2
Lid Gasket – Buna-N	G-1045	G-1045
Lid Gasket – Viton (Optional)	G-1045A	G-1045A

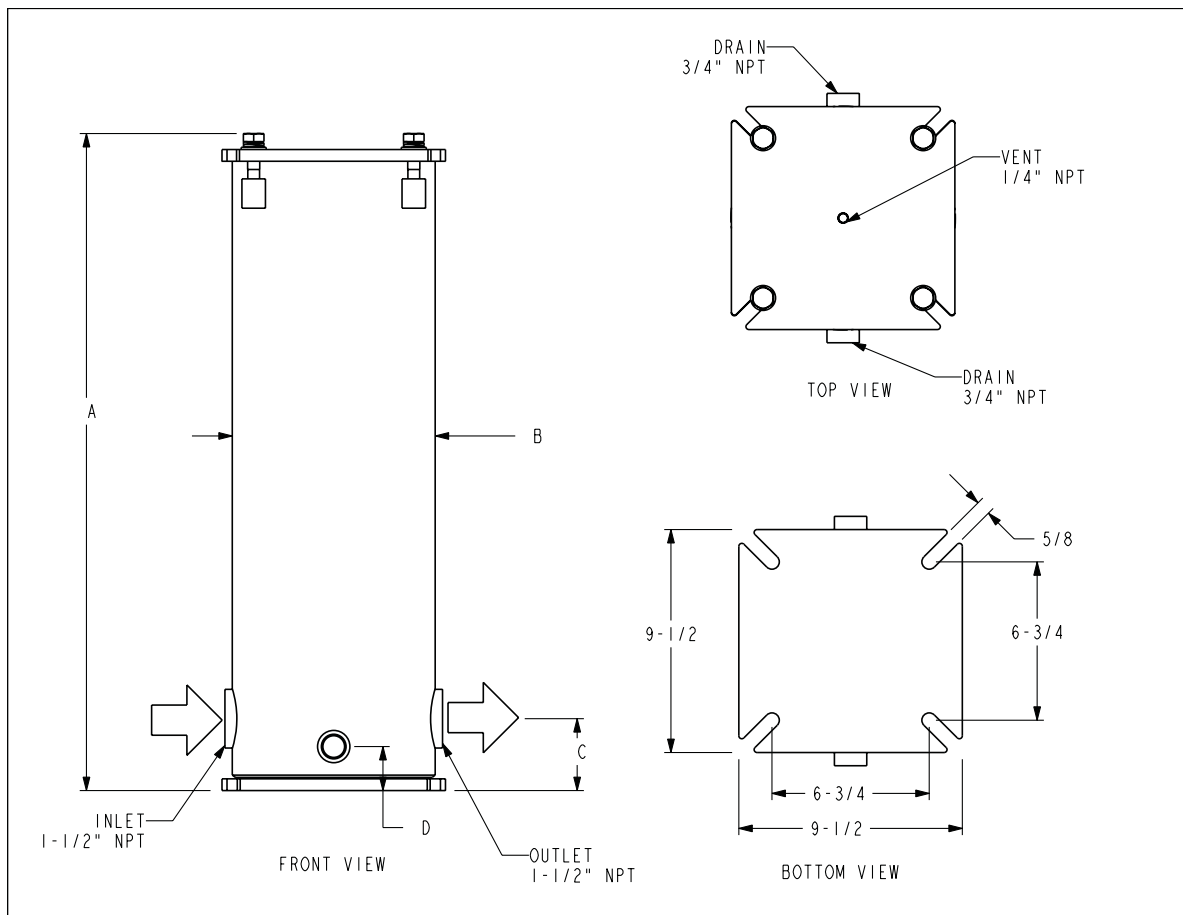

Velcon products are sold and serviced by a world-wide representative network. To order, contact Headquarters or your LOCAL REPRESENTATIVE:

COMPANY HEADQUARTERS:
 Velcon Filters, Inc.
 1210 Garden of the Gods Road
 Colorado Springs, CO 80907-3410
 Phone: 1.800.531.0180 / 1.719.531.5855
 Fax: 719.531.5690
 e-mail: vfsales@velcon.com
 www.velcon.com

MANUFACTURING PLANTS LOCATED AT:
 Colorado Springs, Colorado
 Sylacauga, Alabama

OVERSEAS AFFILIATES:
 Frankfurt/M., Germany & Singapore

**Liquid Filtration
 and Separation
 Specialists**