

DESCRIPTION

Designed to use Velcon's SD-807 and SD-1107 **Superdri**® Cartridges for transformer filling and drying applications. Also accepts Velcon AC-800 Series insulating oil filter cartridges. Single O-ring seal provides leak-free service. Swing bolts with eye nuts offer easy opening of hinged cover. Positive knife edge cartridge seal. Low flow restriction design.

STANDARD FEATURES

- Carbon steel construction
- 100 psi design pressure, 150 psi test
- ASME code design
- Hinged cover with O-ring seal in vessel
- Eye bolt closure
- White polyester polyurethane powder coat, interior and exterior
- Connection size: 2" NPT
- Drain connection: 3/4" NPT
- Top vent connection: " NPT
- PRV connection: 3/4" NPT
- Pressure tap connections: 1/4" NPT (at vessel inlet and outlet)



ORDERING INFORMATION

VF 12 22 SYS 100

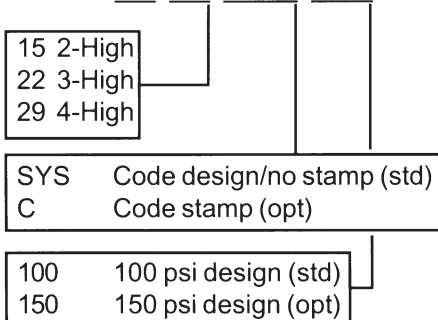

0 - 50 psi DP Gauge 703Y004
Automatic Air Eliminator 440Y404

MAXIMUM RECOMMENDED INSULATING OIL FLOW RATES

HOUSING	CARTRIDGE		
	SD-800	SD-1100	AC-800
VF1215	5 gpm	10 gpm	25 gpm
VF1222	7.5 gpm	15 gpm	38 gpm
VF1229	10 gpm	20 gpm	50 gpm

SPECIFICATIONS

VESSEL	VF1215	VF1222	VF1229
A (vessel ht)	25 ¹ / ₄ "	32 ³ / ₄ "	40 ¹ / ₄ "
B (vessel ht + lid clear)	41 ³ / ₄ "	49 ³ / ₄ "	56 ³ / ₄ "
C (vessel ht + cart clear)	37 ³ / ₄ "	52 ¹ / ₄ "	66 ³ / ₄ "
Weight (empty)	160 lb.	180 lb.	200 lb.
Shipping Weight	190 lb.	210 lb.	230 lb.
Number of Cartridges	2 ea x SD-807	3 ea x SD-807	4 ea x SD-807
	2 ea x SD-1107	3 ea x SD-1107	4 ea x SD-1107
	2 ea x AC-807	3 ea x AC-807	4 ea x AC-807
	1 ea x AC-815	1 ea x AC-822	1 ea x AC-829
Lid Gasket (Std Buna)	G-2031	G-2031	G-2031
Lid Gasket (Opt Viton)	G-2031A	G-2031A	G-2031A

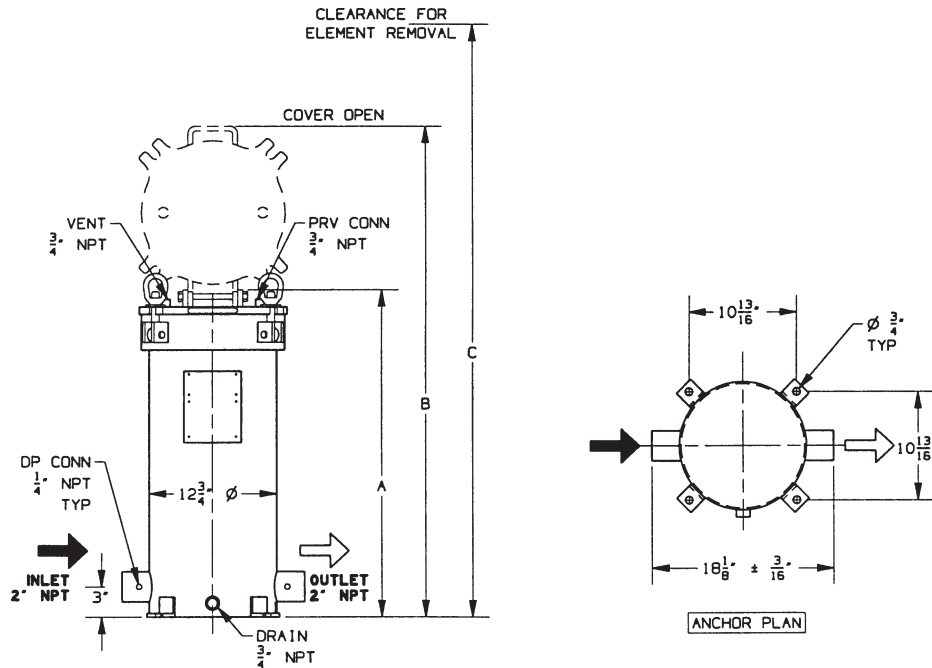

Velcon products are sold and serviced by a world-wide representative network. To order, contact Headquarters or your LOCAL REPRESENTATIVE:

COMPANY HEADQUARTERS:
 Velcon Filters, LLC
 1210 Garden of the Gods Road
 Colorado Springs, CO 80907-3410
 Phone: 1.800.531.0180 / 1.719.531.5855
 Fax: 719.531.5690
 e-mail: vfsales@velcon.com
 www.velcon.com

MANUFACTURING PLANTS LOCATED AT:
 Colorado Springs, Colorado
 Sylacauga, Alabama
 Henryetta, Oklahoma

OFFICES AND AFFILIATES IN:
 Canada, Germany, Singapore & Spain



**Liquid Filtration
 and Separation
 Specialists**

Due to Velcon Filters' continuing product improvement, drawings, specifications and pictures are subject to change without notice.